

Air-Cooled Heat Exchangers

**Application:
API661 Code**

- The outside diameter of cylindrical tubes should be at least 25.4mm
- Minimum required wall thickness of tubes

Tube material	Minimum required wall thickness
Carbon steel or ferritic low-alloy steel (max. 9% chromium)	2.11 mm
High-alloy [austenitic, ferritic and austenitic / ferritic(duplex)] steel	1.65 mm
Non-ferrous material	1.65 mm
Titanium	1.24 mm

• Fin type

L (Knurled)

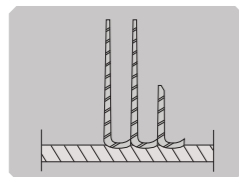

Knurled footed L-shaped aluminium fin wrapped under tension over the outside surface of a tube, while the foot of the fin is simultaneously pressed into the ribbed outer surface of the tube. The fin end at each end of the tube shall be secured to prevent lessening or unravelling of the fins; the vendor shall indicate the method used.

"L" (WRAP-ON)

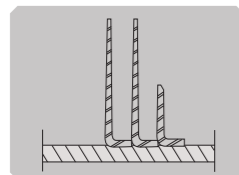

Footed L-shaped aluminium fin wrapped under tension over the outside surface of a tube, with the tube fully covered by the feet between the fins. The fin end at each end of the tube shall be secured to prevent lessening or unravelling of the fins; the vendor shall indicate the method used.

BIMETALLIC EXTRUDED

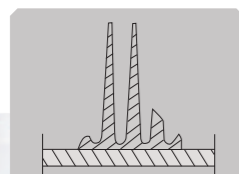

Extruded(integral) an aluminium outer tube from which fins have been formed by extrusion, mechanically bonded to an inner tube or liner.

G (EMBEDDED)

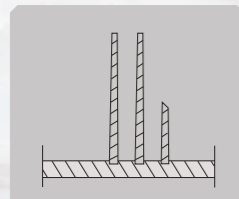

Embedded rectangular cross-section aluminium fin wrapped under tension and mechanically embedded in a groove 0.25 mm ± 0.05 mm (0.010 in ± 0.002 in) deep, spirally cut into the outside surface of a tube. Tube wall thickness is measured from the bottom or the groove to the inside diameter of the tube. The fin end at each end of the tube shall be secured to prevent lessening or unravelling of the fins; the vendor shall indicate the method used.

	"L" Knurled	"L" Wrap-on	Extruded	"G" Embedded
Maxim Working Temperature	250°C/480°F	120°C/250°F	300°C/570°F	400°C/750°F
Atmosphere Corrosion	Acceptable	Acceptable	Acceptable	Resistance
Mechanical Resistance	Acceptable	Acceptable	Excellent	Acceptable

• Fin Minimum Stock Thickness

Fin Height	Fin Minimum Stock Thickness
< 12.7 mm	0.35 mm
≥ 12.7mm	0.4 mm

▶ Engineering technology for the future

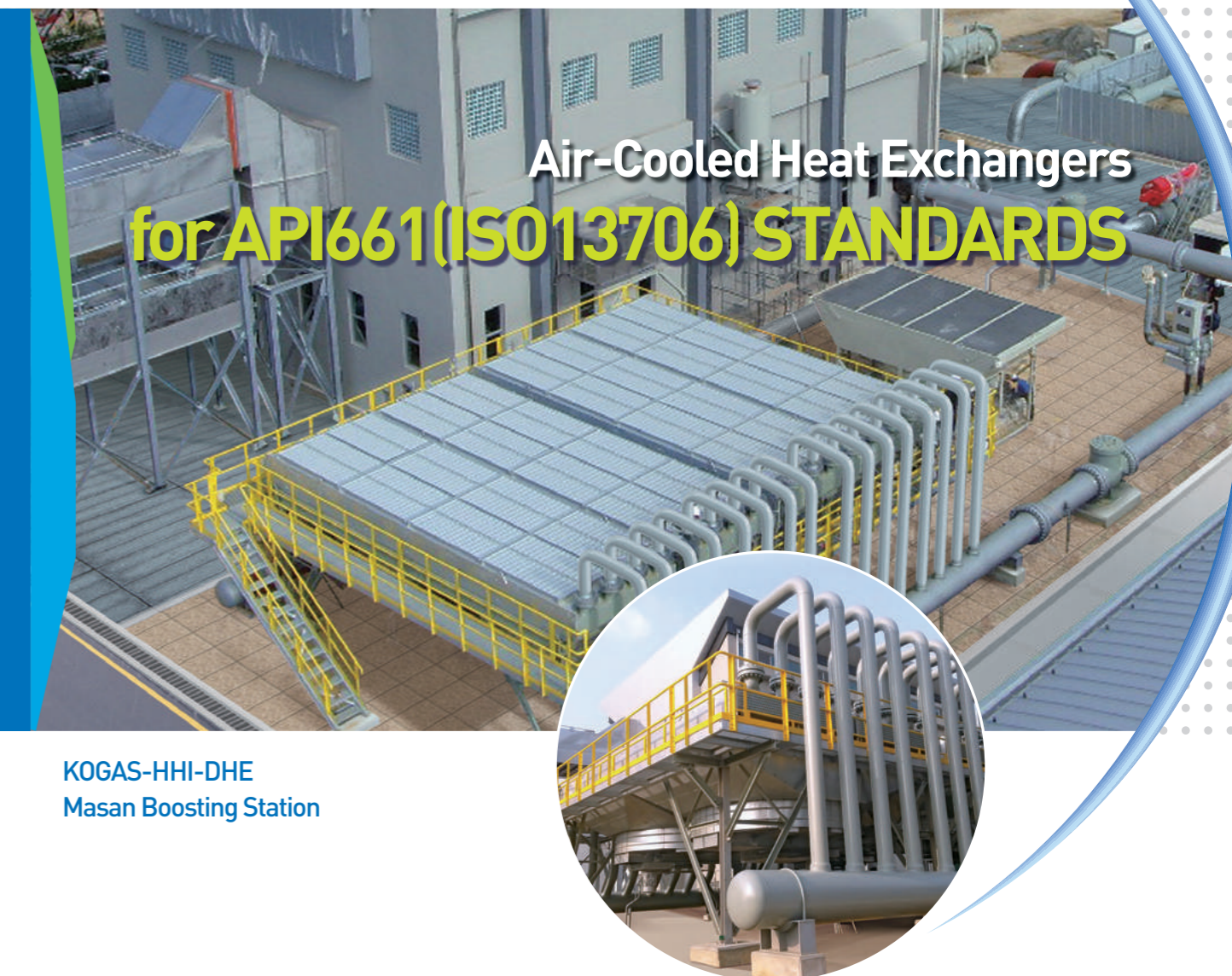

KOGAS-HHI-DHE
Masan Boosting Station

DongHwa Entec

Head Office and Factory

7, Noksansandan 261-ro, Gangseo-gu, Busan, Korea
TEL : +82-51-970-1000 FAX : +82-51-970-1001

Hwajeon Office and Factory

20, Hwajeonsandan 1-ro 63beon-gil, Gangseo-gu, Busan, Korea
TEL : +82-51-970-1100 FAX : +82-51-970-0710

R&D Center

7, Gwahaksandan-ro 305beon-gil, Gangseo-gu, Busan, Korea
TEL : +82-51-970-0711 FAX : +82-51-970-0730

DongHwa Entec (Shanghai) Co., Ltd.

No.2508 JiangShan Road Luchoogang Shanghai 201308 P.R.China
TEL : +86 (0)21-5197-5001 FAX : +86 (0)21-5197-5005

Sister Company

DongHwa Machinery & Engineering Co., Ltd.

173, Hwajeonsandan 1-ro, Gangseo-gu, Busan, Korea
TEL : +82-51-971-3455 FAX : +82-51-971-5450
www.donghwame.com

DongHwa Pneutec

36, Noksansandan 261-ro, Gangseo-gu, Busan, Korea
TEL : +82-51-974-4800 FAX : +82-51-831-3772
www.dhkomp.co.kr

Air Cooled Heat Exchanger (Gas, Oil, Water & etc)

Picture for Parts



Shop Facilities for Production



List of Certificates

ASME American Society of Mechanical Engineers, USA (PP, S, U, U2)

NATIONAL BOARD The National Board of Boiler & Pressure Vessel Inspectors (PP, S, U, U2)

SELO Manufacture License of Special Equipment People's Republic of China

ANSI American National Standard Institute, USA

TEMA Tubular Exchanger Manufacturers Association, USA

DIN Deutsche Industrie Normen, GERMANY

JIS Japanese Industrial Standard, JAPAN

KS Korean Industrial Standard, KOREA

API American Petroleum Institute



Forced-draught

Exchanger designed with the tube bundles located on the discharge side of the fan

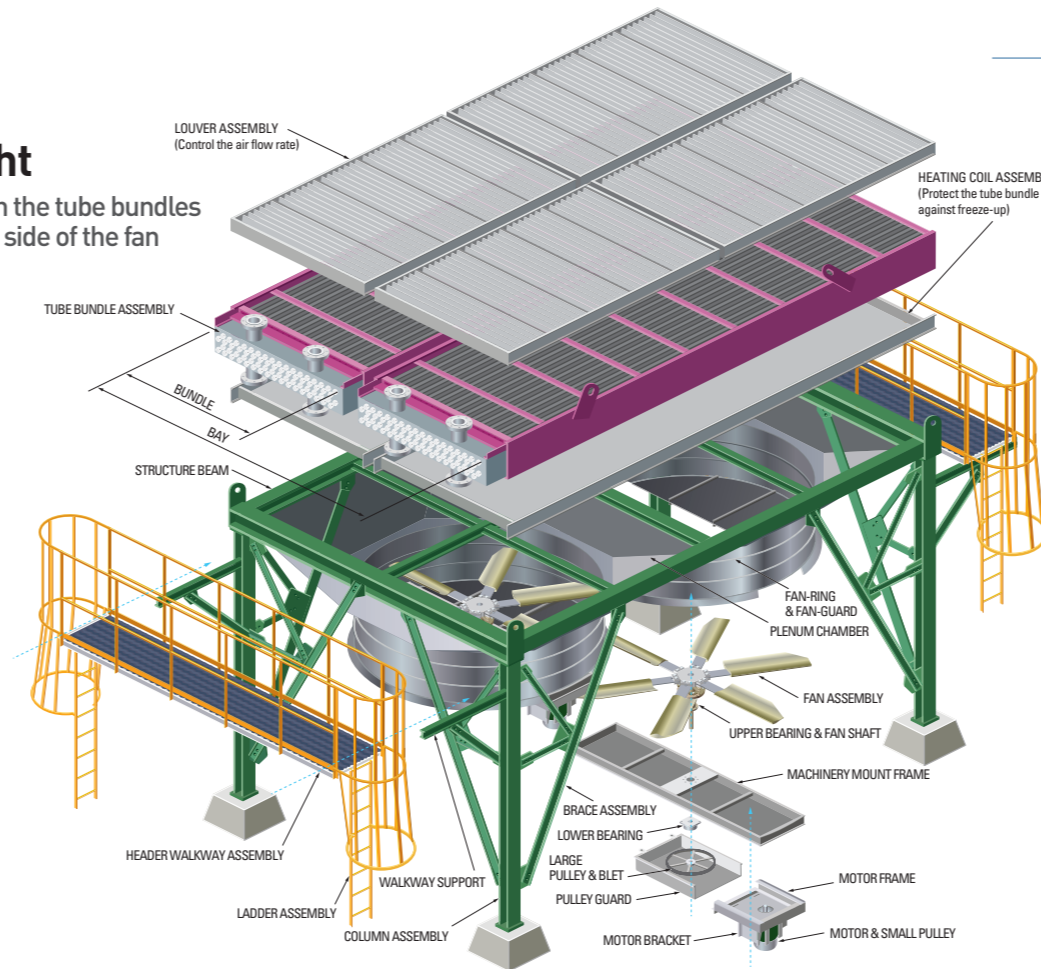

Induced-draught

Exchanger designed with the tube bundles located on the suction side of the fan

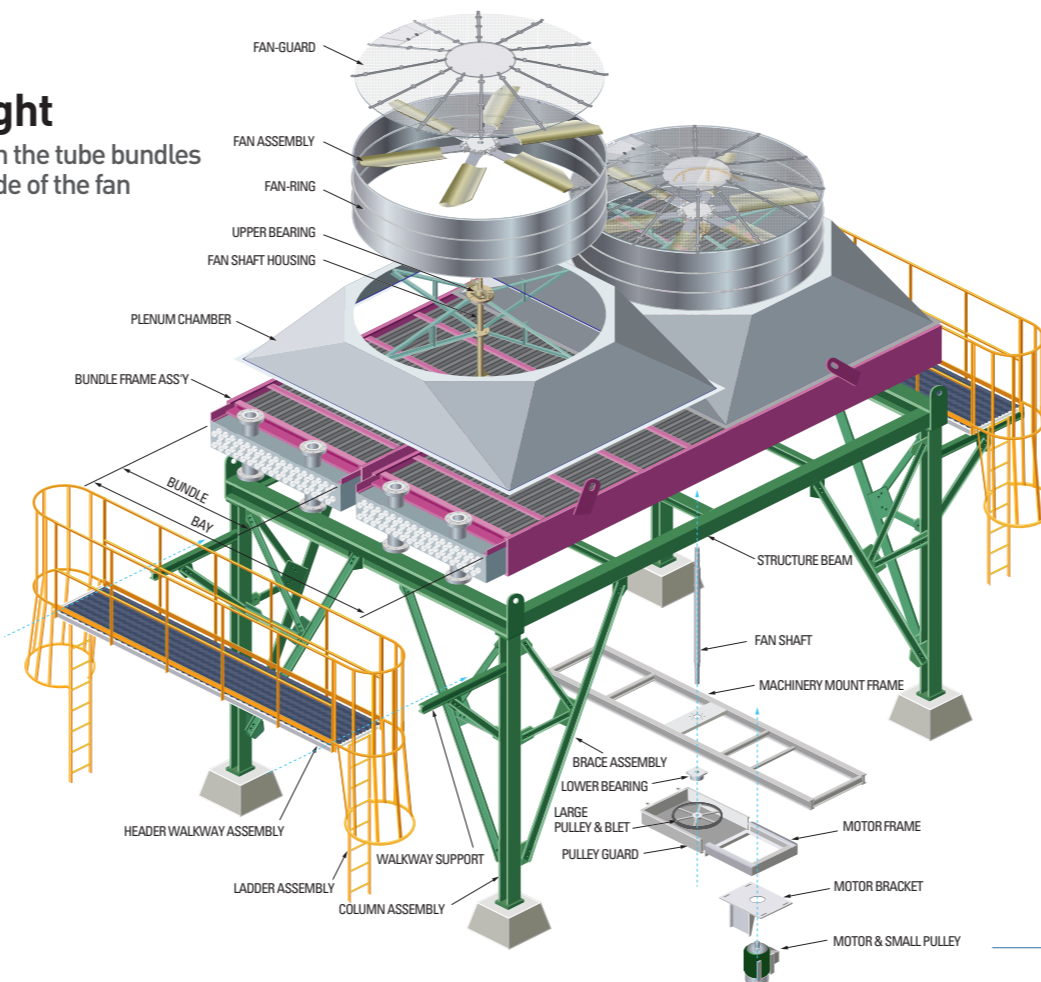

Main Parts

Headers

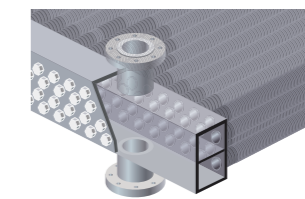

Plug headers (Max. working pressure 350 bar)
Threaded plug holes shall be provided opposite the ends of each tube for access. Holes shall be threaded to the full depth of the plug sheet. Figure shows typical construction of a tube bundle with plug headers.

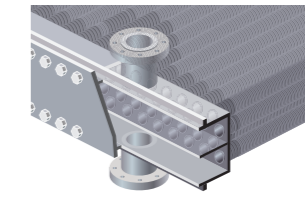

Removable cover plate (Max. working pressure 40 bar)
The cover plate header design shall permit removal of the cover without disturbing header piping connections. Figure shows typical construction of tube bundles with removable cover plate headers.

Belts and Pulley

PowerGrip® GT@3 Belt Drives
PowerGrip GT3 drives provide positive, trouble-free power transmission in low speed high torque applications and offer many advantages over conventional chain, gear and other belt drives.

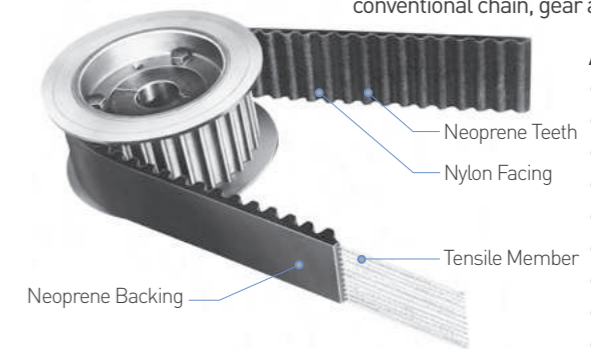

- Advantages:**
- Higher capacity
 - Improved registration
 - Reduced noise
 - No lubrication required
 - No stretching due to wear
 - Corrosion resistance
 - Excellent abrasion resistance
 - Clean operation
 - Long trouble-free service

Design Code Capabilities

- * ASME Code
- * European PED
- * China SELO
- * API Code
- * Korea KGS / KOSHA
- * TEMA R,C and B
- * Russian GOST
- * ALL CLASS
- * Others Country Local Code (Algeria, Singapore, ...)

Capability

- * Max. Length : 18 m
- * Max. Width : 8 m
- * Max. 200 Ton
- * Production Capacity : 150 Bundles/Year

Fans

• Auto Fan

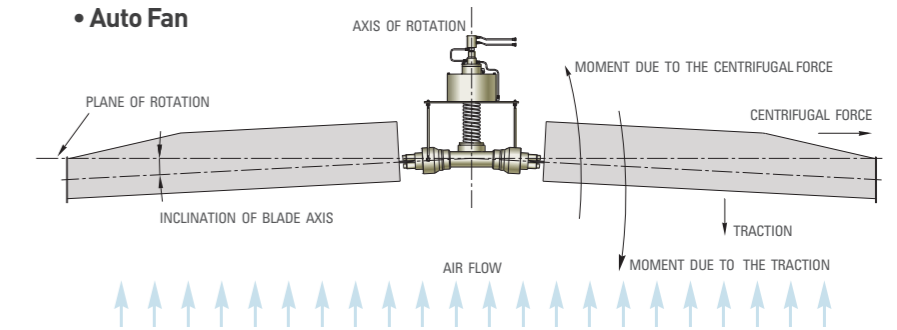

• Manual Fan

