



ISO 9001
Certificate No. A 0858
ISO 14001
Certificate No. B 0110
OHSAS 18001
Certificate No. C 0082



www.dh.co.kr

▶▶ Engineering technology for the future

Double Effect Type Water Maker & Fresh Water Generator



Our company endeavor ceaselessly
to develop new products
and quality improvement



DongHwa Entec

DOUBLE EFFECT TYPE WATER MAKER

DF 35/60/2 Fresh Water Generator



Introduction

The DongHwa Double Effect Type Water Maker is the equipment that convert seawater or exhausted dirty water to pure water for drinking, boiler make-up, domestic use on ship and small power station.

At that time, seawater is evaporated at about 70°C, 45°C respectively as the one passed the inside of heater under the high vacuum condition and the separated pure vapor is converted to freshwater on condenser.(stage2)

The other one is going to the heating medium of heater and then converted to freshwater.(stage 1)

Operating Principle

The DongHwa Double Effect type water maker utilizes the waste heat from diesel engine jacket cooling water to convert seawater into freshwater by evaporating under low vacuum condition.

The DongHwa Double Effect Type water maker is based on 3sets of Titanium plate heat exchangers as stage 1 evaporator, condenser and stage 2 evaporator respectively.

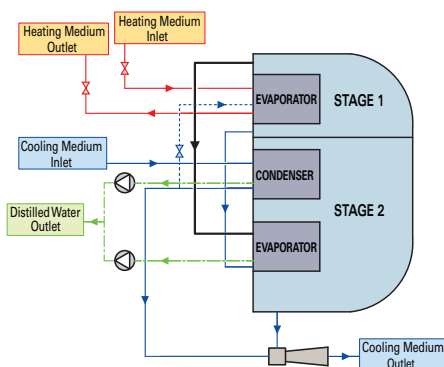

The evaporation chamber are kept under vacuum by a water ejector driven by the seawater outlet from the evaporator. The feed water evaporators when entering the evaporators due to the vacuum condition.

Water spray and droplet are partly removed from the vapor by the deflector mounted on top of each evaporator and partly by a built-in demister.

The separated water droplets fall back into the brine, which is extracted from the lower part of the unit by means of the ejector.

The desalted vapor passing through the demister will be sucked into the condensers where it will be condensed by means of cold incoming seawater.

The pure distilled water will be taken out by means of freshwater pump.

The pure water taken out from the condensers will be controlled by a salinometer to supervise that the salinity level be satisfactory. If the salinity exceeds the preset level, the solenoid valve in the discharge line of the distiller pump is automatically activated and faulty distillate is dumped into the drain.

The salinometer has a built-in alarm and can be connected as remote alarm so that a too high salinity is registered immediately in the control room or where else needed.

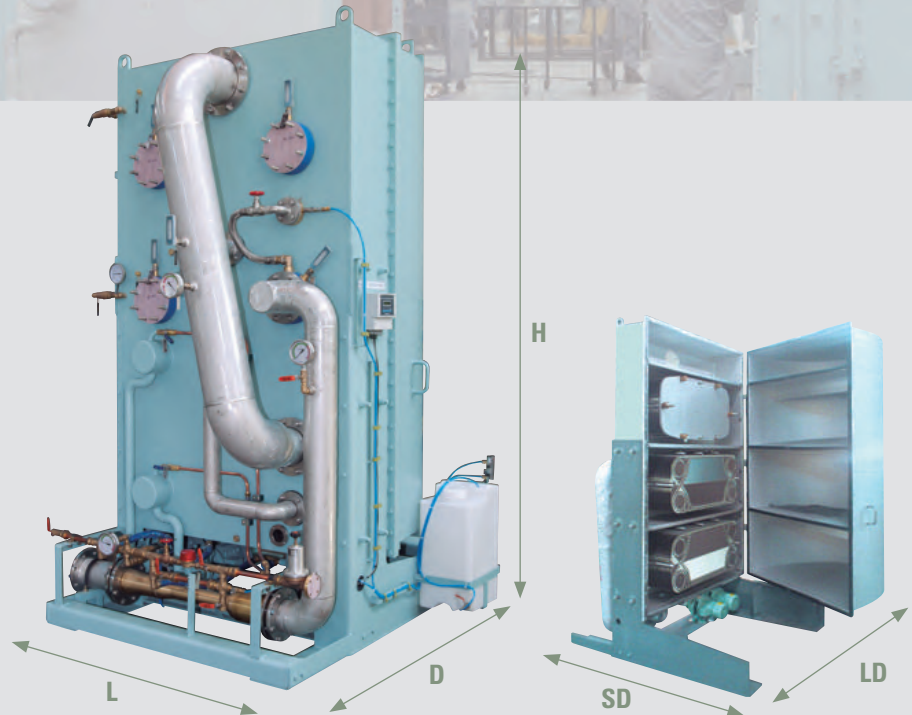

Main Feature

DF35/60/2	L (mm)	D (mm)	H (mm)	SD (mm)	LD (mm)	Weight (kg)
	1480	1740	2800	1727	2427	2985

Advantage

- Low installation costs
- Reduced space requirement
- Simple, unattended operation
- Reliability
- Easy operation & maintenance
- Versatility for a wide range of applications
- Fresh water quality

Application

- Offshore Vessel
(Drillship, Semi-Submizable Rig...)
- Onshore remote location
- Fishing Vessel
- Cruiser

Option

- Sea Water Ejector pump
- Electric Booster Heater with Control Panel
- Control panel with motor starters
- Additional control equipment for easy running



Fresh Water Generator



Tubular Type

Working Principle

The main engine jacket cooling water circulates the outside of the vertical tube in heating section and the sea water to be distilled is sent to the bottom cover of this section. Then some of the sea water is converted into vapour when it goes up through the heated tubes.

The vapour, through the demisters, is condensed on the outer surface of the tubes of the distilling condenser and the resultant distillate is led to the suction of the distillate pump. In the meantime the non-condensable gases and brine are extracted and discharged to overboard by the combination ejector.

Technical Specification of DX-a Type

Capacity	Type	Connection	Jacket water flow 80°C	Heat consumption	Ejector pump capacity	Ejector pump consumption(60Hz)	FW pump consumption(60Hz)	
							m ³ /24hr	KW
5	DX-a -5	65	13	141	13×4.8	5.5	2	0.4
10	DX-a -10	80	26	282	24×4.8	6.6	3	1.5
15	DX-a -15	80	37	423	35×4.8	11	3	1.5
20	DX-a -20	100	54	564	44×4.8	11	3	1.5
25	DX-a -25	100	56	705	61×4.8	15	3	1.5
30	DX-a -30	125	69	846	75×4.8	18.5	3	1.5
35	DX-a -35	125	80	987	75×4.8	18.5	3	1.5
40	DX-a -40	125	85	1128	90×4.8	22	3	1.5

● Installation sketch of Fresh Water Generator

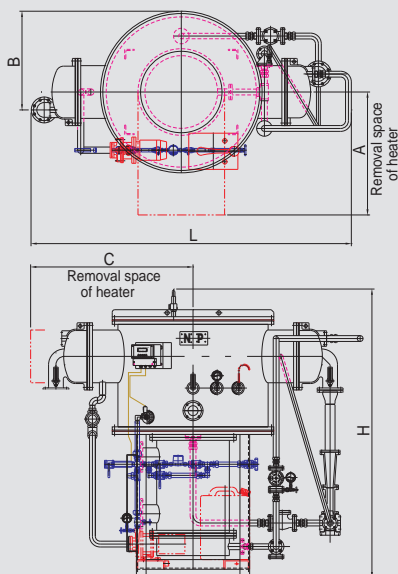
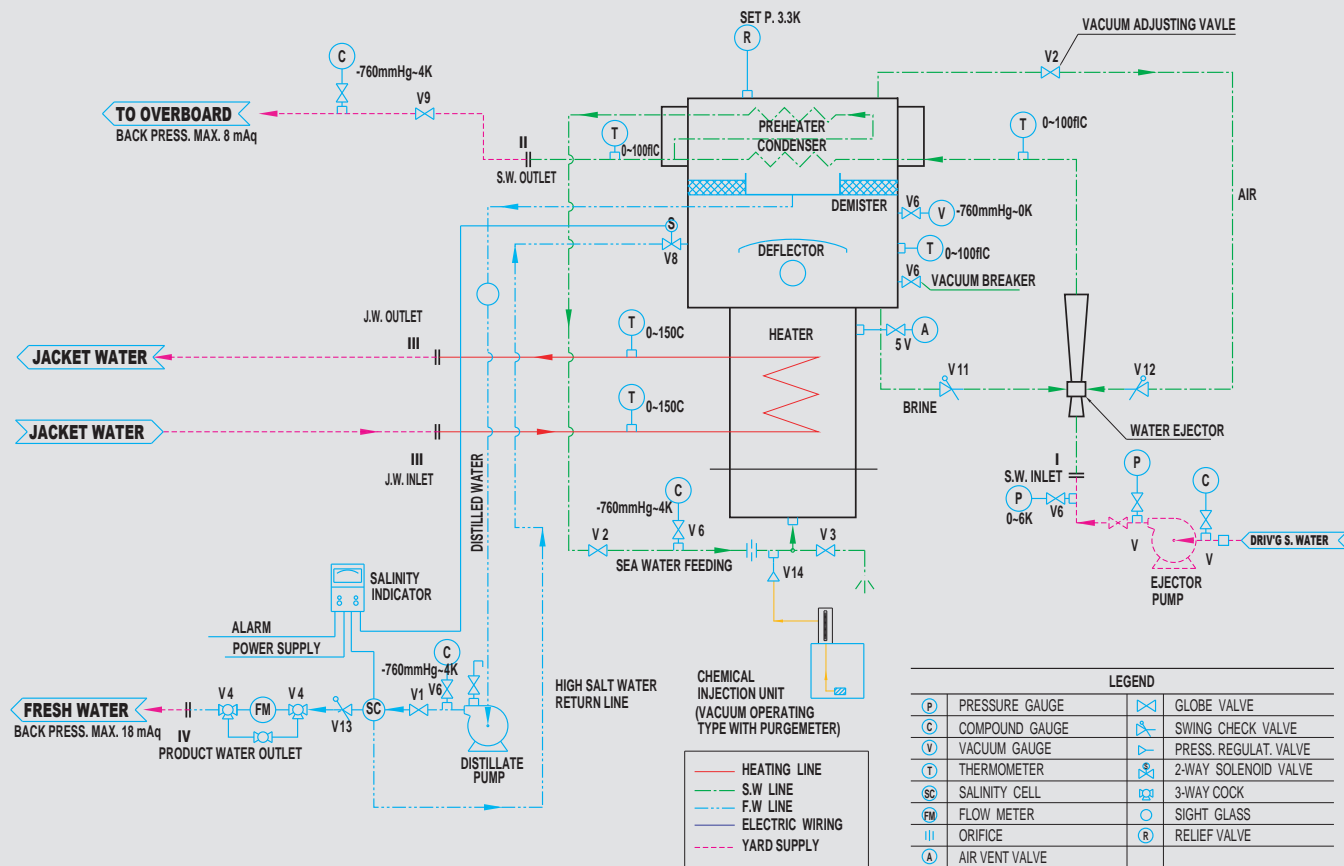

● Dimension List

Type	L	B	H	C	A	Approx. Weight(kg)		
						Empty	Operation	Ejector P/P
DX-a -5	1480	820	1430	1655	650	680	780	120
DX-a -10	1680	980	2005	1840	830	750	900	120
DX-a -15	1835	1030	1975	2030	850	850	1000	128
DX-a -20	1880	1060	1680	2250	990	1140	1350	140
DX-a -25	2050	1150	1850	2310	1200	1145	1370	175
DX-a -30	2250	1330	2080	2470	1500	1150	1400	175
DX-a -35	2400	1380	2100	2510	1500	1200	1570	175
DX-a -40	2500	1400	2205	2550	1500	1320	1650	187

Fresh Water Generator



Plate Type

● Working Principle

The DongHwa Entec DF Series Fresh Water Generator utilizes the heat from diesel engine jacket cooling water to produce pure drinkable water by evaporating sea water under high vacuum enabling the feed water to evaporate at temperatures below 48°C. Steam can also be used as the heat source instead of the hot jacket water.

The DongHwa Entec DF Series Fresh Water Generator is based on 2 titanium plate heat exchangers acting as an evaporator and a condenser respectively.

The evaporation chamber is kept under vacuum by a water ejector driven by the sea water outlet from condenser.

A part of this heated sea water is used as feed water for the evaporator. The feed water evaporates when entering the evaporating chamber due to the vacuum condition. Water spray and droplets are partly removed from the vapour by the deflector mounted on top of the evaporator and partly by a build-in demister. The separated water droplets fall back into the brine, which is extracted from the sump by means of the ejector pump.

The desalted vapour passing through the demister will be sucked into the plate condenser where it will be condensed by means of cold incoming salt water.

The pure distilled water will be taken out by means of an integral fresh water pump. The pure water taken out from the condenser will be controlled by a salinometer to supervise that the pre-set salinity(1~10ppm) will be reached. If the salinity exceeds the specified level, the solenoid valve in the discharge line of the distiller pump is automatically activated and the faulty distillate is returned to the feed line.

● Technical Specification of DF Type

Capacity	Type	Connection	Jacket water flow (m ³ /24hr)			Heat consumption	Ejector pump capacity	Ejector pump consumption (60Hz)	FW pump consumption (60Hz)	
			80°C	85°C	90°C				bar	KW
m ³ /24hr	Single stage	JIS	80°C	85°C	90°C	KW	m ³ × bar	KW	bar	KW
3	DF3	40	8	6	5	110	8×4.0	3.6	3.0	0.75
5	DF3	40	10	8	6	160	13×4.0	4.8	3.0	0.75
7	DF7	40	12	10	8	220	18×4.0	6.6	3.0	0.75
10	DF7	65	24	20	15	310	24×4.0	6.6	3.0	0.75
12	DF7	65	26	23	16	360	29×4.0	11.0	3.0	0.75
15	DF13	65	34	30	22	460	35×4.0	11.0	3.0	0.75
18	DF13	65	38	35	25	540	40×4.0	11.0	3.0	0.75
20	DF13	65	44	40	30	600	44×4.0	11.0	3.0	0.75
25	DF13	80	54	48	35	750	58×4.0	15.0	3.0	0.75
30	DF23	100	75	67	50	910	75×4.0	18.5	3.0	1.5
35	DF23	100	80	75	55	1080	88×4.0	22.0	3.0	1.5
40	DF35	125	86	80	60	1220	92×4.0	22.0	3.0	1.5
45	DF35	125	100	90	68	1360	95×4.0	22.0	3.0	1.5
50	DF35	150	112	100	74	1520	120×4.0	22.2	3.0	1.5
60	DF35	200	132	118	90	1850	140×4.0	24.0	3.0	1.5

● Installation sketch of Fresh Water Generator

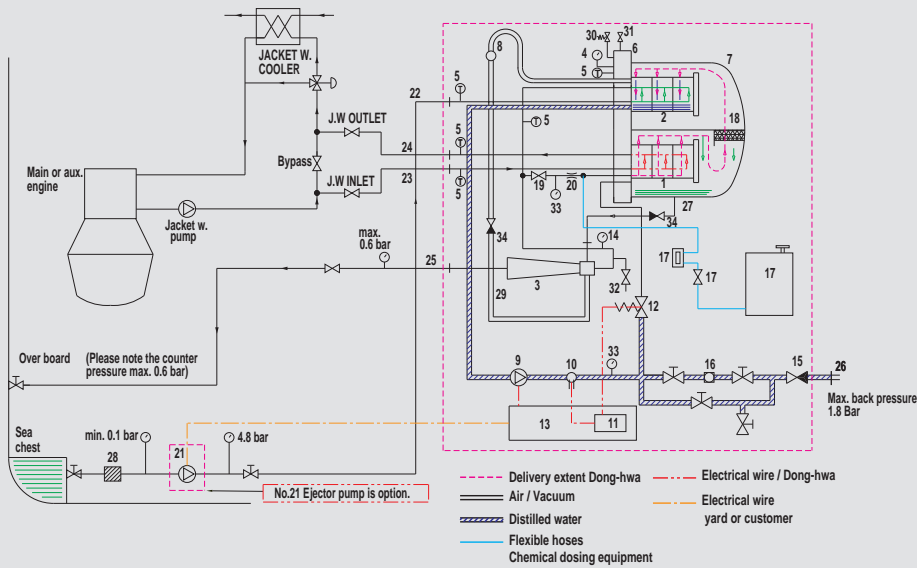

NO.	DESCRIPTION	NO.	DESCRIPTION
1	EVAPORATOR	18	DEMISTER
2	CONDENSER	19	FEED VALVE
3	TWIN EJECTOR	20	ORIFICE
4	VACUUM GAUGE	21	EJECTOR PUMP(Optional)
5	THERMOMETER	22	SEA WATER INLET
6	DISTILLER BASE FLANGE	23	JACKET WATER INLET
7	DISTILLER COVER	24	JACKET WATER OUTLET
8	FLOW SIGHT GLASS	25	SEA WATER OUTLET
9	FRESH WATER PUMP	26	DISTILLED WATER OUTLET
10	SALINITY SENSOR	27	BRINE OUTLET
11	SALINITY INDICATOR(controller)	28	SEA WATER FILTER (Max. 5mm)
12	SOLENOID V/V	29	AIR / VACUUM SUCTION LINE
13	CONTROL PANEL	30	SAFETY VALVE
14	PRESSURE GAUGE	31	VACUUM BREAKER
15	PAN CHECK VALVE	32	DRAIN LINE VALVE
16	FLOW METER FOR DISTILLED WATER	33	COMPOUND GAUGE
17	CHEMICAL DOSING UNIT	34	CHECK VALVE

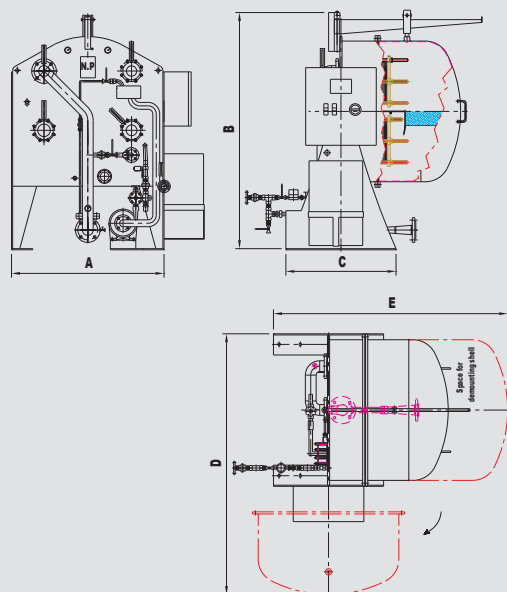
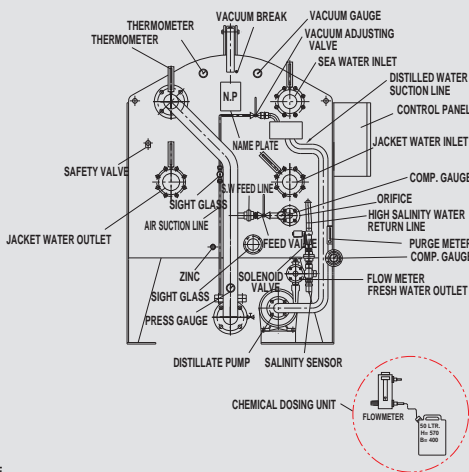
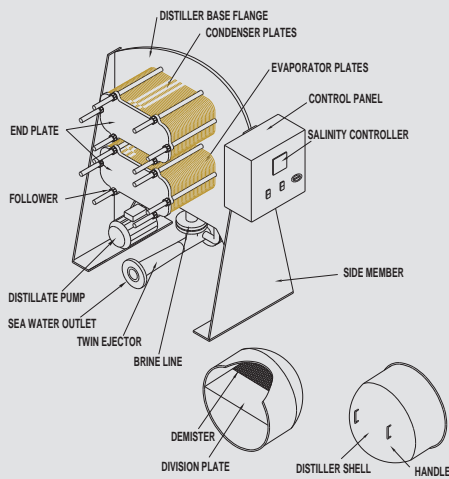

● Dimension List

Type	A	B	C	D	E	Approx. Weight(kg)	
						Empty	Operation
DF3/5	610	1013	810	935	1460	310	400
DF7/10	1020	1400	808	1042	1500	400	550
DF13/15	1020	1550	625	1065	1435	430	580
DF13/20	1080	1660	780	1280	1550	450	600
DF13/25	1080	1660	780	1450	1820	640	850
DF23/30	1276	1838	1210	1785	2255	675	900
DF23/35	1276	2100	900	1440	1710	700	950
DF35/40	1276	2200	900	1590	1810	850	1100
DF35/45	1276	2200	900	1700	2000	890	1200
DF35/50	1276	2200	900	1750	2100	910	1250
DF35/60	1276	2200	900	1800	2200	1130	1500



Head Office and Factory (Land Area: 15,574 m² / Building Area: 13,845 m²)



Hwajeon Office and Factory (Land Area: 20,127 m² / Building Area: 20,087 m²)



Energy - Environmental Tec. Lab. (Land Area: 4,465 m² / Building Area: 3,365 m²)



Donghwa Entec (Shanghai) Co., Ltd. (Land Area: 33,350 m² / Building Area: 18,457 m²)

DongHwa Entec

Head Office and Factory

7, Noksansandan 261-ro, Gangseo-gu, Busan, Korea
TEL : +82-51-970-1000 FAX : +82-51-970-1001

Hwajeon Office and Factory

20, Hwajeonsandan 1-ro 63beon-gil, Gangseo-gu, Busan, Korea
TEL : +82-51-970-1100 FAX : +82-51-970-0710

Energy - Environmental Technology Laboratory

7, Gwahaksandan-ro 305beon-gil, Gangseo-gu, Busan, Korea
TEL : +82-51-970-0711 FAX : +82-51-970-0730

Subsidiary Company

DongHwa Pneutec

75, Mieumsandan-ro 8beon-gil, Gangseo-gu, Busan, Korea
TEL : +82-51-974-4800 FAX : +82-51-974-4899

DongHwa Giyeon

80, Mieumsandan-ro 8beon-gil, Gangseo-gu, Busan, Korea
TEL : +82-51-899-9600 FAX : +82-51-899-9670

DongHwa Entec (Shanghai) Co., Ltd.

No.2508 JiangShan Road Luchaogang Shanghai 201308 P.R.China
TEL : +86 (0)21-5197-5001 FAX : +86 (0)21-5197-5005

GAS Entec Co., Ltd.

No. #812, 813 and 814, Ace Hitech21, 48, Centum jungang-ro,
Haeundae-gu, Busan, Korea
TEL : +82-51-714-3308 FAX : +82-70-7500-3979